

- CONSERVATION GUIDANCE SHEET -

# DESIGN GUIDE: TRADITIONAL CASEMENT WINDOWS

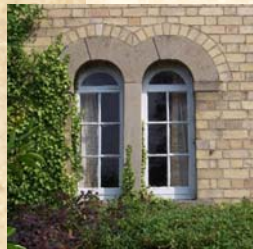

*Windows can be thought of as the 'eyes' of a building. A good or bad choice of replacement window can transform the character of your building, often to a surprising degree. Great care and understanding is needed if any changes are proposed.*

*The casement is a common type of window, where the opening part is hinged, usually on a vertical edge. Casement windows take many forms, varying due to things like the date, locality and status of a building.*

*This is a guide to the history, conservation and design of traditional timber casement windows in our area.*





## HISTORY

Successor to the stone mullioned window, the traditional timber casement became the most common window type by the second half of the eighteenth century. Subdivided by glazing bars, joining together the small panes of glass, the earlier designs had the opening part of the window, the 'casement', made of iron with lead laticing to the glass. By around 1840, the beginning of the Victorian period, the frames and opening casements were made entirely of timber.

Windows of 6-panes per casement were the most common pattern, but designs were occasionally elaborated by the use of Gothic arches or smaller panes, especially during the mid-nineteenth century. From then, though, glass technology improved and the number of panes per casement was reduced to two with one horizontal glazing bar. Traditional windows usually were no wider than about 450mm(18") per casement.

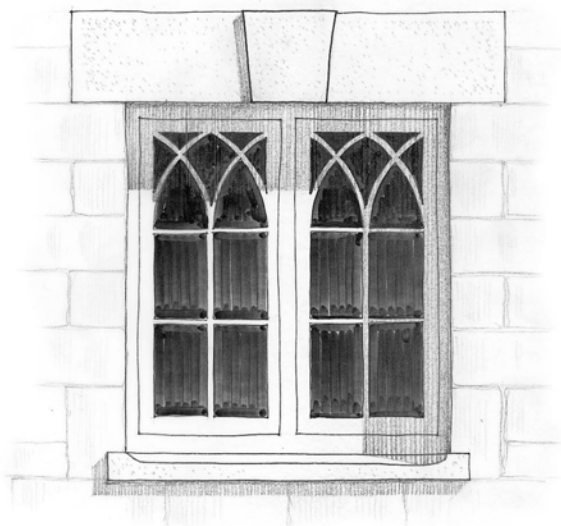

## CONSTRUCTION

The timber frame of casement windows was developed from the heavy oak frames of medieval openings. Jambs, cill and head were jointed with a pegged mortice and tenon. A slimmer softwood version of this construction forms the basis of the traditional casement window.

In a typical window, a glazing rebate is formed allowing the glass to be fixed from the outside face and be held in place with sprigs and putty. A little sophistication was introduced by means of moulding the inner edge of the frame where it adjoins the glass, the glazing bars being moulded to match, and the fixed frame was often also moulded.

In traditional construction, mouldings meet at mitred corners: they were never routered after assembly, rounding the inner edges, as is common today.

## GLASS

Until Crown Glass and Cylinder Sheet became available, the small panes of Broad Sheet had to be fixed together in leaded lights, and later by the use of glazing bars. The newer glass-making processes produced much larger sheets although many imperfections occurred, and these can often be seen in the poorer quality glass used in cottage casements. Modern Polished Plate glass has no imperfections, and has none of the special character of the older material.

## FITTINGS

The ironmongery attached to casements consists of the hinges, the casement latch, and the stay bar. As with the latches found on earlier iron casements, these fittings were often made by the local village blacksmith and can be very distinctive. By the late nineteenth century, cheaper factory-produced fittings were available.





# Typical glazing bar mouldings

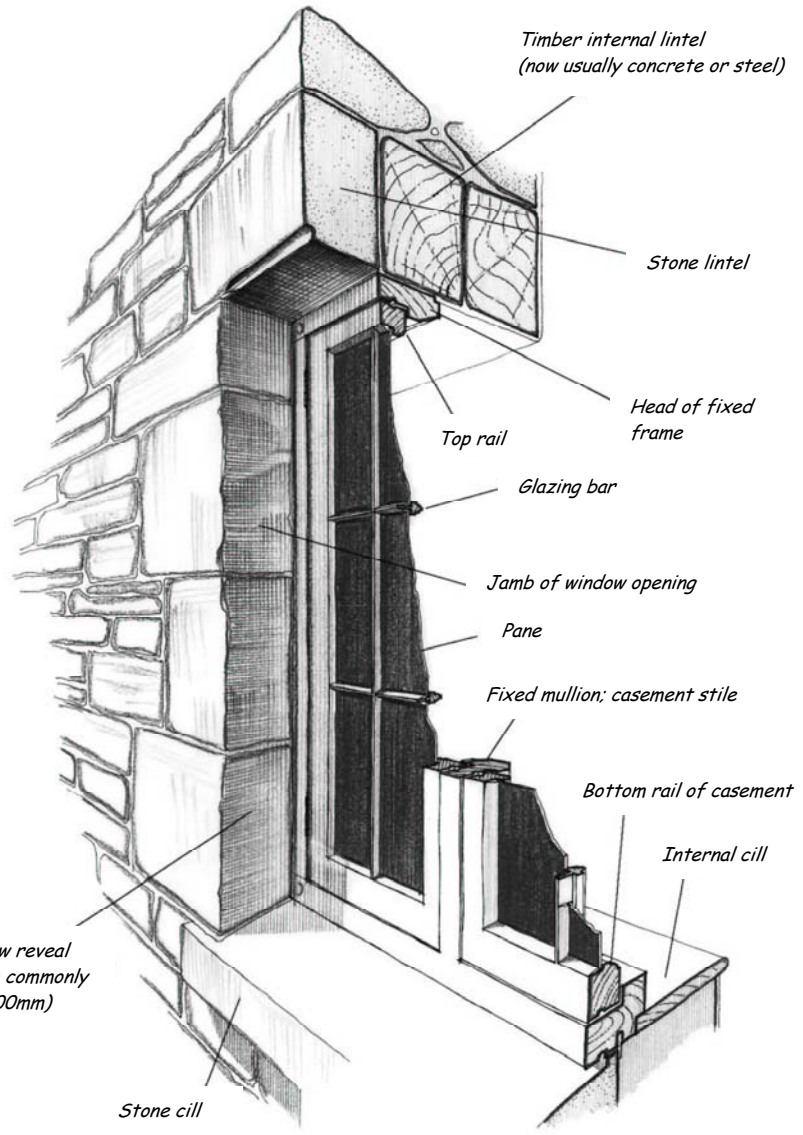
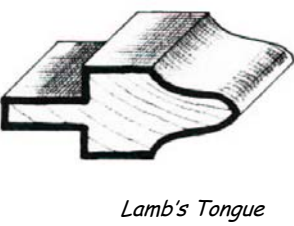
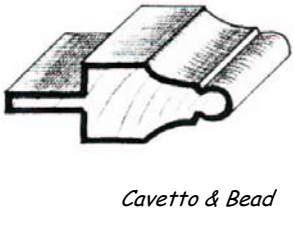
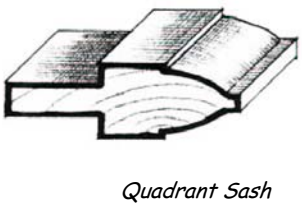
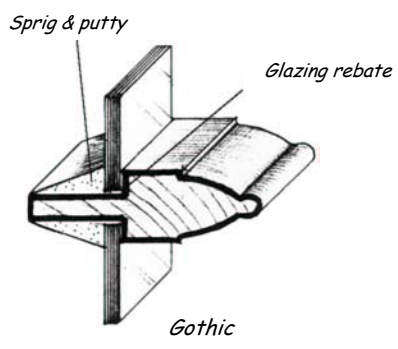

## Variations in the head and cill treatments

How the window sits within its opening can also make or break the character of an elevation. If you are adding or altering windows, it is worth having a close look at others on your building or nearby, to see what the local traditions for constructing window heads, cills and reveals are. The depth of reveals (how far back from the front of the wall the window sits) can vary according to local styles and the age of the building.

The exact detailing of even the most basic of brick arched window and door heads can be very locally distinctive – particularly in the Severn Vale, where the construction can vary from village to village.

The varying quality of stone in the District has also led to different designs for stone arched window heads. Those found close to Stroud, Stonehouse and the Cotswold escarpment are generally formed from larger blocks ('voussoirs') than in the south and east. They also typically have large, specially shaped blocks at either end of the arch, as illustrated on the cover of this guide.

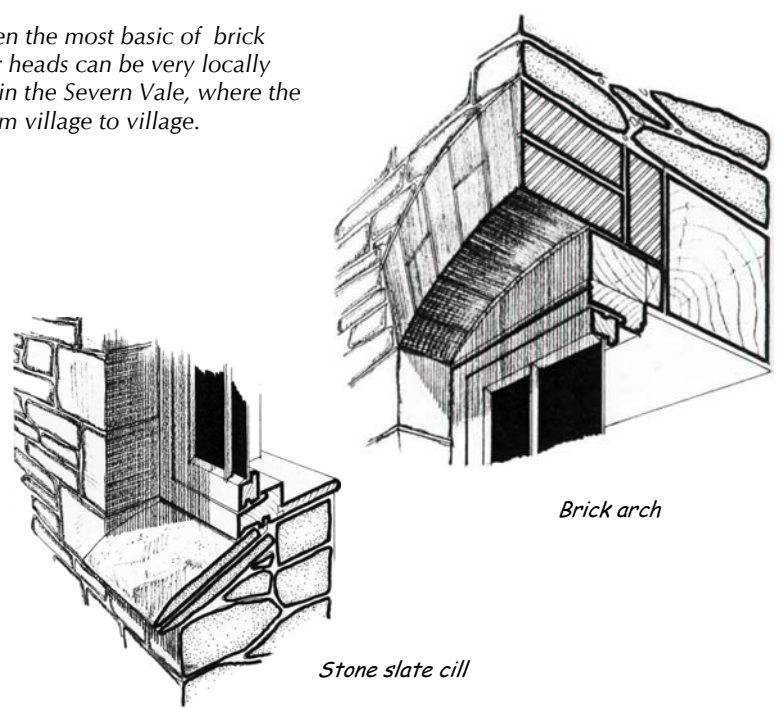
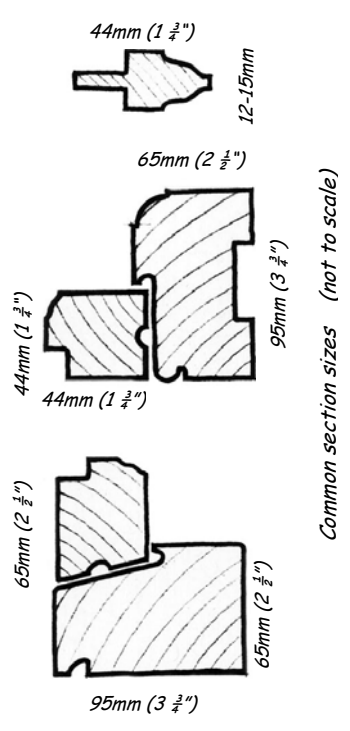

## PAINT COLOUR



Although the very earliest casements were made of oak, and therefore left unpainted, nineteenth-century softwood casements were always painted. Staining is not a traditional finish for windows and is best avoided, especially on listed buildings.

White was the most common colour, although historically whites were never as brilliant as modern paints can be. Colour has always been used, though. A common tradition, mostly surviving in the Severn Vale today, was for window frames to be painted in a strong colour (often blues, greens, black or deep red), while the opening lights of the casement were painted white. The colour contrast emphasizes the delicacy of fine details such as the glazing bars. Many estates adopted particular shades as an easy-maintenance livery for all their buildings – commonly cream, pale blue, grey and slate green in the Cotswold area. Some estate colours are still in use today. Traditions such as these can create a real sense of local distinctiveness.

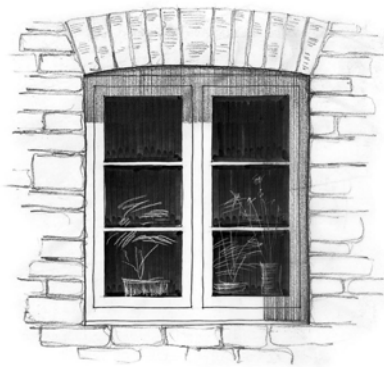

## CONSERVATION AND LISTED BUILDINGS

Although this guidance leaflet is primarily intended to provide advice on how to design new casement windows to match the appropriate local style, old windows should always be retained and repaired wherever possible, especially when the building is 'listed'. Often the only fault will be a rotten cill, and any good joiner will be able to replace this. Old glass and ironmongery should also be retained, unless beyond repair.

Modern casement designs should always be avoided. Usually these have opening casement frames that overlap the fixed frame externally, and where the fixed light is directly glazed to this outer frame creating an unbalanced effect.

When selecting windows for sensitive locations, such as on listed buildings or in conservation areas, the joinery details described in this leaflet should be followed.

Most changes to windows on listed buildings, other than very minor repairs, will require listed building consent – including 'like for like' replacement. It is a criminal offence to carry out any alteration to a listed building without having obtained prior listed building consent.

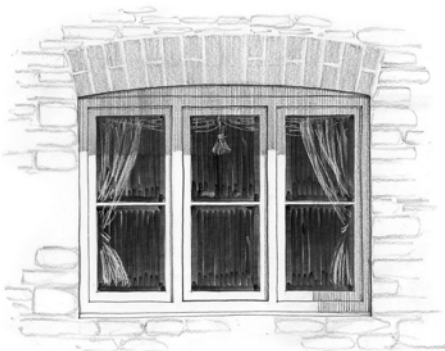

Planning policy guidance note, PPG15: 'Planning and the Historic Environment' contains Government policy in relation to historic buildings (this can be found on the Planning pages of the government's website: [www.communities.gov.uk](http://www.communities.gov.uk)). Annex C provides specific guidance on windows.

**The Repair of Wood Windows**, a leaflet published by SPAB. Available from SPAB, 37 Spital Square, London E1 6DY. Tel: 0207 377 1644.

**L1B Conservation of Fuel and Power in Existing Dwellings (2006)**, a guidance booklet on applying Part L. Available from English Heritage, Customer Services Dept., PO Box 569, Swindon, SN2 2YP (quote product ref: 50675). email:customers@english-heritage.org.uk

The Conservation Team,  
Development Services,  
Stroud District Council Offices,  
Ebley Mill, Westward Road,  
Stroud, Glos. GL5 4UB

Telephone: 01453 766321  
[www.stroud.gov.uk](http://www.stroud.gov.uk)



**STROUD DISTRICT COUNCIL**  
[www.stroud.gov.uk](http://www.stroud.gov.uk)

With thanks to Cotswold  
District Council.  
This guidance sheet is based  
upon their document  
'Traditional Casement  
Windows – Design Guide'



# TRADITIONAL CASEMENT WINDOWS

## Technical Guide 1 Single Glazing

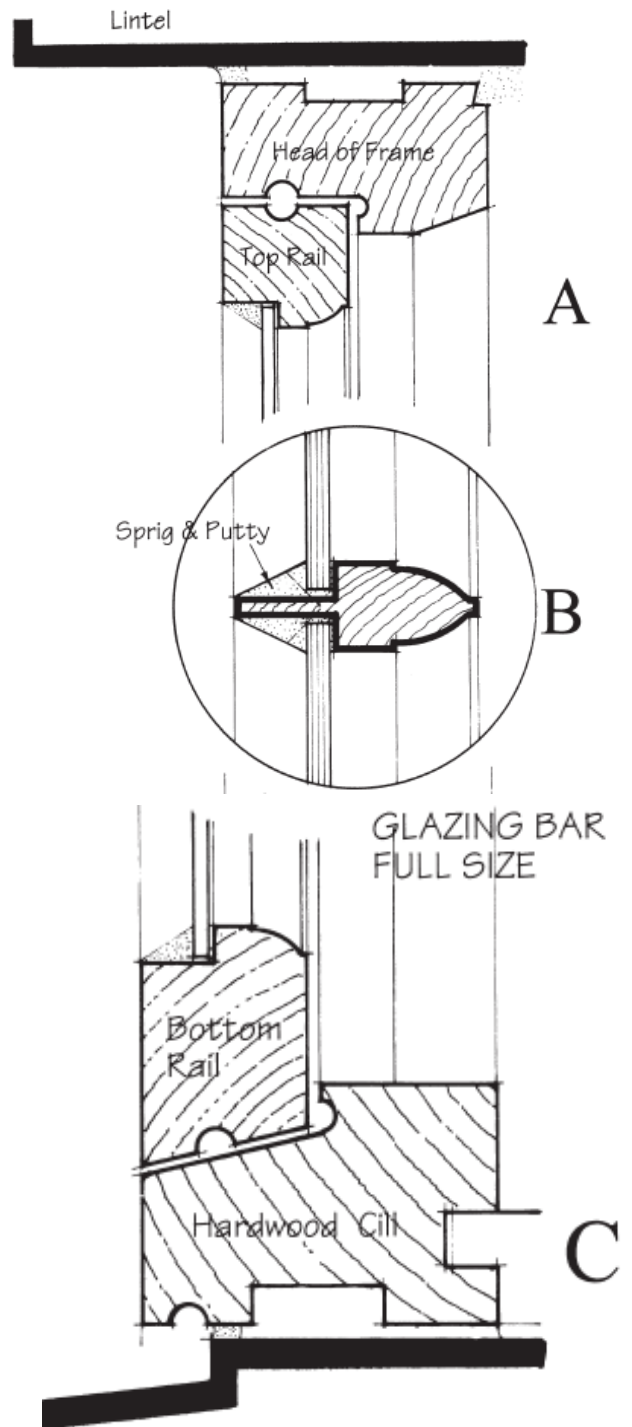
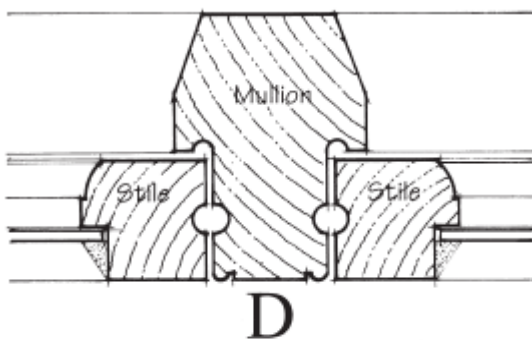
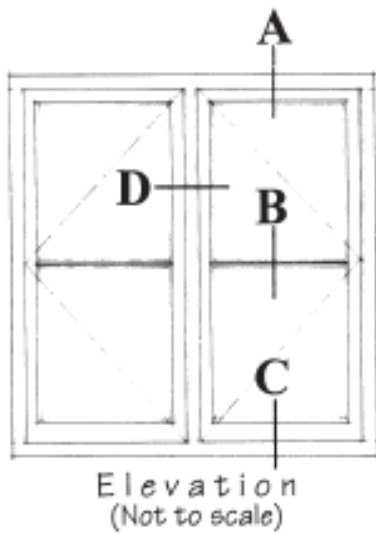

STROUD DISTRICT COUNCIL

October 2006

For further advice and information contact:

The Conservation and Design Team  
or Building Control  
Development Services  
Stroud District Council Offices, Ebley Mill,  
Westward Road, Stroud, Glos. GL5 4UB

[www.stroud.gov.uk](http://www.stroud.gov.uk)

Planning Enquiries: 01453 754442

## Technical Guide 1 Single Glazing

This technical guide is intended to provide supplementary information to the *Traditional Casement Windows-Design Guide*. The drawings overleaf illustrate an example of how a modern window can be detailed in a way which reflects the general pattern of traditional single glazed casement windows, as are found throughout the District.

### Building Regulations

To satisfy the requirements of Part F 1 *Means of Ventilation* of the Building Regulations 1991, suitable ironmongery can be fitted which secures the opening casements in an open position thus providing background ventilation. This avoids the need for modern 'trickle' vents within the window frame and ventilation openings within the fabric of the wall. (See fig 1)

Since 1<sup>st</sup> April 2002 (and recently updated in 2006), part L has applied to existing buildings, as well as to new build. Consequently, you will now need to apply for Building Regulations approval for the replacement of any existing windows as well as for entirely new windows.

However, Part L provides for the protection of the special characteristics of historic buildings. When replacing windows, "...the aim should be to improve energy efficiency where and to the extent that it is practically possible... always provided that the work does not prejudice the character of the historic building, or increase the risk of long-term deterioration to the building fabric or fittings" (Part L1B Section 9). This allows for the replication of existing single glazed windows, because the original windows are often important to a building's character. Where the existing windows on an historic building are modern or are the result of earlier inappropriate alterations, Part L also allows for the installation of new single-glazed windows that have been designed to restore the character of the building.

Please note, however that in certain circumstances (for example where a building is to be erected, substantially altered or extended), the use of single glazed casements may not be acceptable under Building Regulations.

Draught stripping can be fitted in the frames of the opening elements of the window. The major benefit of draught stripping is that these improvements can be made at a low cost, and with no noticeable visual to the window. (See fig. 2)

If the window is provided as a means of escape in the event of an emergency, the requirements of Part B 1 Means of Escape **must be** satisfied. Nearly always a design solution can be found which satisfies this requirement while retaining the overall design and appearance of a traditional casement window. (See fig 3)

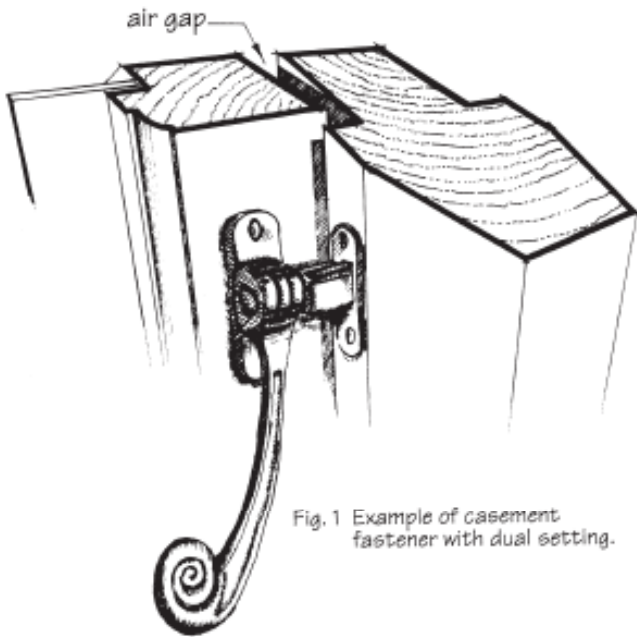

Fig. 1 Example of casement fastener with dual setting.

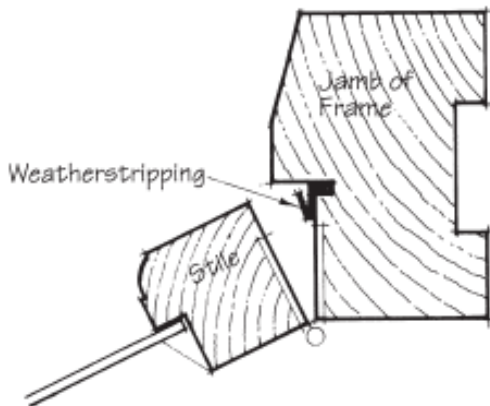

Fig. 2 Example of weatherstripping.

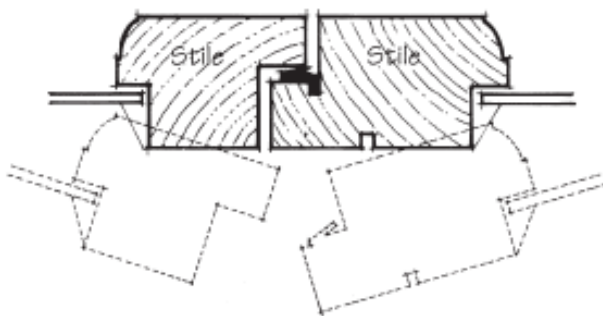
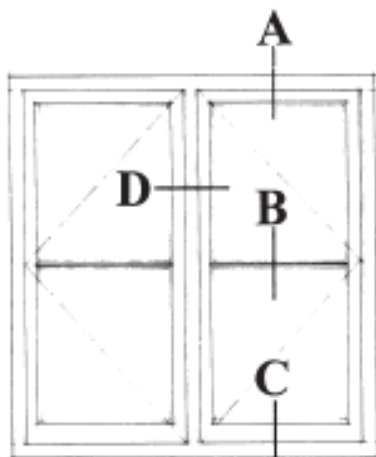

Fig. 3 Example of escape window with stile of opening casement incorporating fake mullion.

# TRADITIONAL CASEMENT WINDOWS

## Technical Guide 2 Double Glazing



Elevation  
(Not to scale)

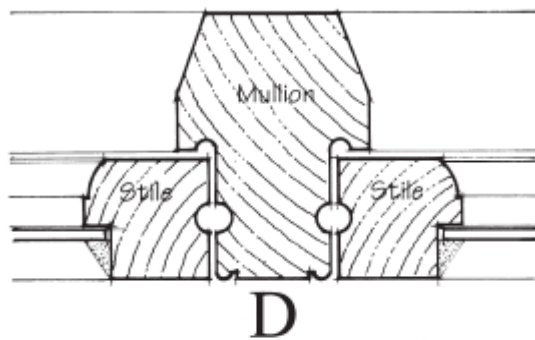

D

It is important to note that the Government's PPG 15 states in Paragraph C. 50 that: 'It is usually impossible to install double-glazed units in existing frames or to replicate existing frames with new sealed units without making noticeable changes...new glass in such units may also significantly alter the appearance of the window. **Such changes are rarely acceptable in listed buildings.**'

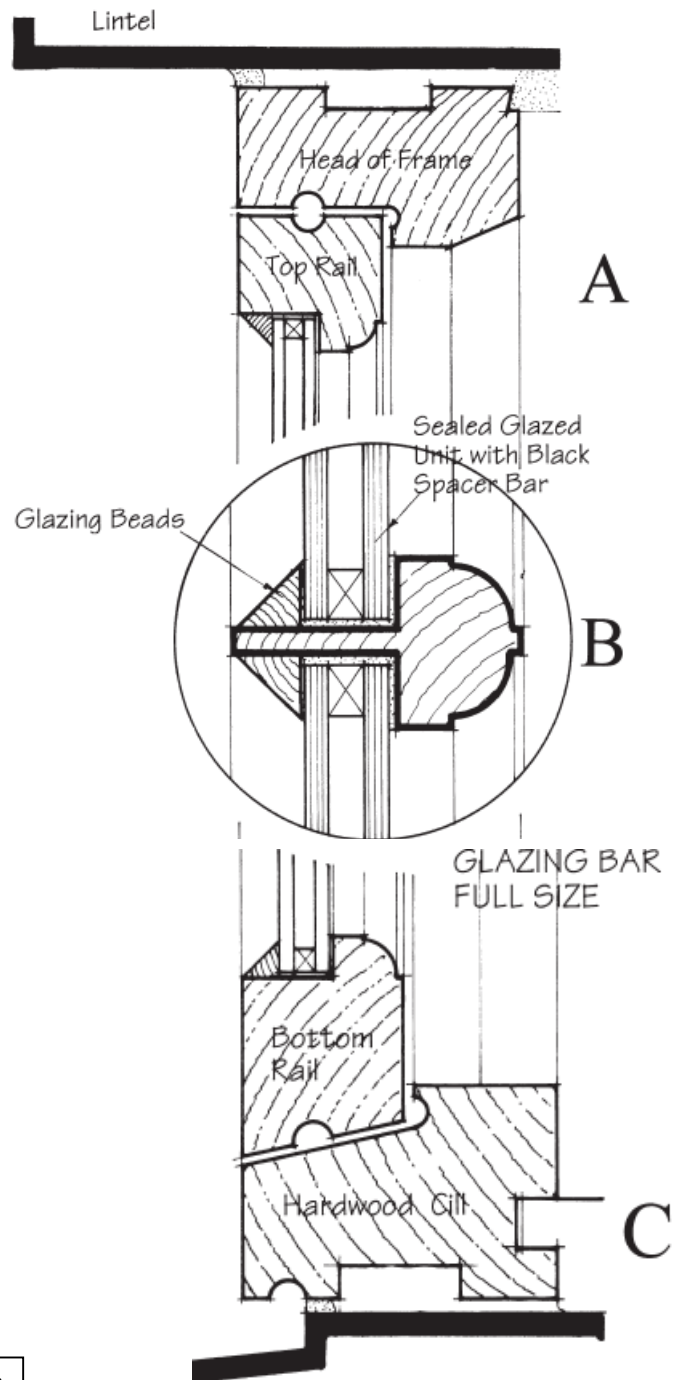

STROUD DISTRICT COUNCIL

October 2006

For further advice and information contact:  
The Conservation and Design Team  
or Building Control  
Development Services  
Stroud District Council Offices, Ebley Mill,  
Westward Road, Stroud, Glos. GL5 4UB

[www.stroud.gov.uk](http://www.stroud.gov.uk)  
Planning Enquiries: 01453 754442

## Technical Guide 2 Double Glazing

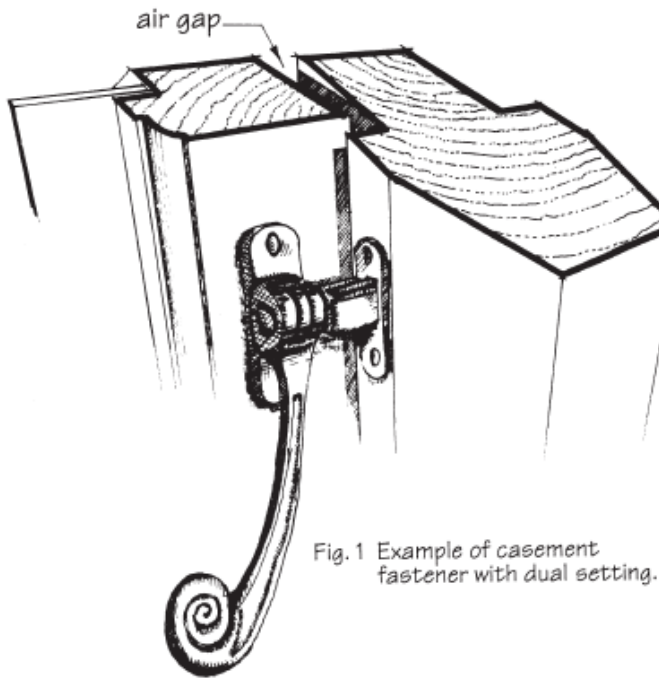

Fig. 1 Example of casement fastener with dual setting.

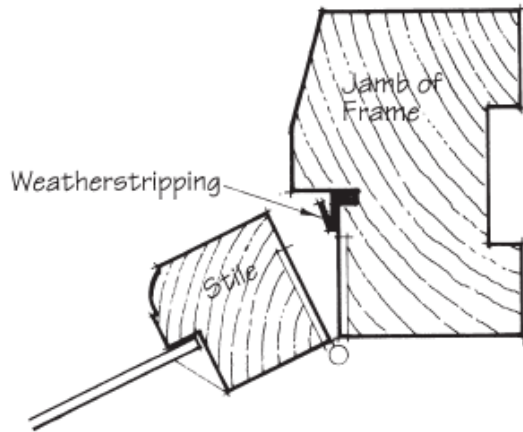

Fig. 2 Example of weatherstripping.

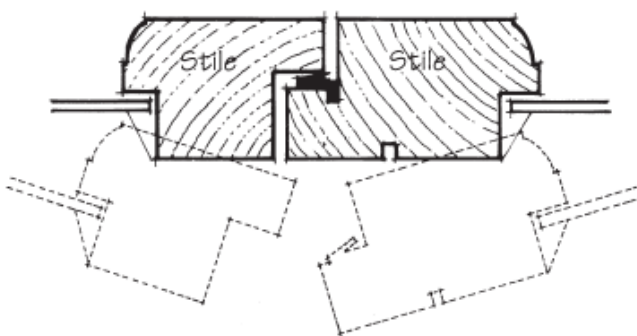

Fig. 3 Example of escape window with stile of opening casement incorporating fake mullion.

This technical guide is intended to provide supplementary information to the Traditional Casement Windows-Design Guide. The drawings overleaf illustrate how, if required, a window can be double glazed while retaining a traditional appearance. Please note that in certain situations, for example on listed buildings, the use of double-glazed casements may not be acceptable, due to the effect of the appearance and detailing of the window.

With selected double glazed units the need to reduce timber sections to sizes comparable with traditional windows presents the designer with several problems. It is impossible to replicate a traditional casement window when using double-glazing without making noticeable changes to the profiles of glazing bars, stiles and rails. Where a window is designed for a building, which is less sensitive to these changes, double-glazing may be acceptable.

### Building Regulations

To satisfy the requirements of Part F1 *Means of Ventilation* of the Building Regulations 1991, suitable ironmongery can be fitted which secures the opening casements in an open position thus providing background ventilation. This avoids the need for modern 'trickle vents' within the window frame and ventilation openings within the fabric of the wall. (See fig 1)

Since 1<sup>st</sup> April 2002 (and updated in 2006), Part L has applied to existing buildings as well as to new build. Consequently, you will now need to apply for Building Regulations approval for the replacement of any existing windows, as well as for entirely new windows. These will be expected to comply with the requirements of Part L, which is often assumed to mean that double-glazing is the only option.

The 2006 edition of L1B states that those buildings which are **exempt** from energy efficiency requirements, are those buildings which are 'listed in accordance with section 1 of the Planning (Listed Buildings and Conservation Areas) Act 1990' it goes on to state that this is because 'compliance with the energy efficiency requirements would unacceptably alter the character or appearance' (Section 5).

Double-glazed units can be supplied in a variety of thickness. It is the air-gap, which dictates the thermal efficiency of the window. By using combinations of standard and high performance glass and an Argon gas within the sealed unit, it is possible to satisfy the requirements of Part L (a) *limiting the heat loss through the fabric of the building* of the Building Regulations, while keeping the thickness of the glazing and the casement frame to an absolute minimum, achieving a somewhat traditional appearance. As with single-glazed windows, the use of draught stripping will greatly reduce the rate of heat loss through casements and reduce draughts and noise. (See fig. 2)

If the window is provided as a means of escape in the event of an emergency, the requirements of Part B 1 *Means of Escape* **must be** satisfied. Nearly always a design solution can be found which satisfies this requirement while retaining the overall design and appearance of a traditional casement window. (See fig. 3)



